



voestalpine Stahl, Linz, Austria

Maximized Emission Reduction Of Sintering – SIMETAL^{CIS} MEROS plant

Metals Technologies

SIEMENS
VAI 

Meeting future environmental demands now!

The challenge:

Requirements placed on availability, process quality and productivity of sinter plants are continuously growing, and can only be met with designs suitable for the rugged iron and steelmaking environment. At the same time, a growing number of environmental regulations necessitate extensive investment. This especially affects sinter plants with their high quantity of emissions, which has become a focal point of authorities responsible for environmental protection. As plant designers, our job is to create concepts that offer the best possible solution serving environmental requirements and economical necessity simultaneously. While significant potential for new investment is available in the growing markets of eastern Europe, Asia and India, industrial nations are concentrating more on plant modernizations and reducing environmental impact.

Our solution:

A fully satisfactory, environmentally compatible solution for the treatment of the offgas arising during the sintering process has not existed up until now. In response to this challenge, Siemens VAI Metals Technologies recently developed the SIMETAL^{CLIS} MEROS[®] process which stands for Maximized Emission Reduction Of Sintering. In a series of successive treatment steps the dust and harmful metallic and organic components present in the sinter offgas are removed to levels previously unattained with conventional gas-treatment techniques.

Process operations and operating parameters were confirmed during two years of performance of the SIMETAL^{CLIS} MEROS demonstration plant. This was followed by the construction of the world's first SIMETAL^{CLIS} MEROS industrial plant which started up at the sinter plant of voestalpine Stahl, Linz/Austria in August 2007.

Achieved results:

- **Fast start-up for high-quality production –**
Project implementation: 16 months
- **Highest plant availability –**
More than > 99%
- **Environmentally friendly sinter plant –**
Dust emissions: < 5 mg/Nm³
- **Flexible and reliable –**
Long filter bag lifetime

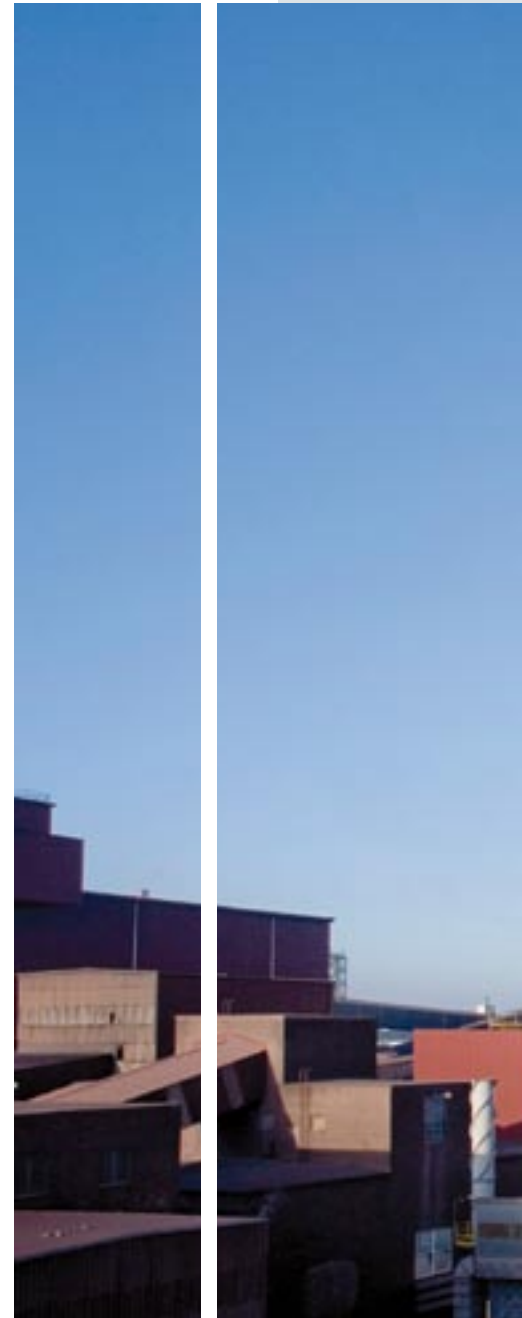



The customer

Name:
voestalpine Stahl GmbH

Location:
Linz, Austria

Sinter production:
2,8 mio t/a

Services:
voestalpine Stahl GmbH, the steel center of competence within the voestalpine corporate group, is an important supplier to the European automotive, household appliance and construction industries. voestalpine Stahl GmbH manufactures high-quality flat steel products for the following industries:

- Automotive and utility vehicle industry
- Automotive supply industry
- Household appliance industry
- Electrical industry
- Trade/SSC
- Tubes/sections/cold rollers
- Construction and building supply industry
- Mechanical engineering industry

SIMETAL^{CIS} MEROS plant

The environmentally friendly sinter plant

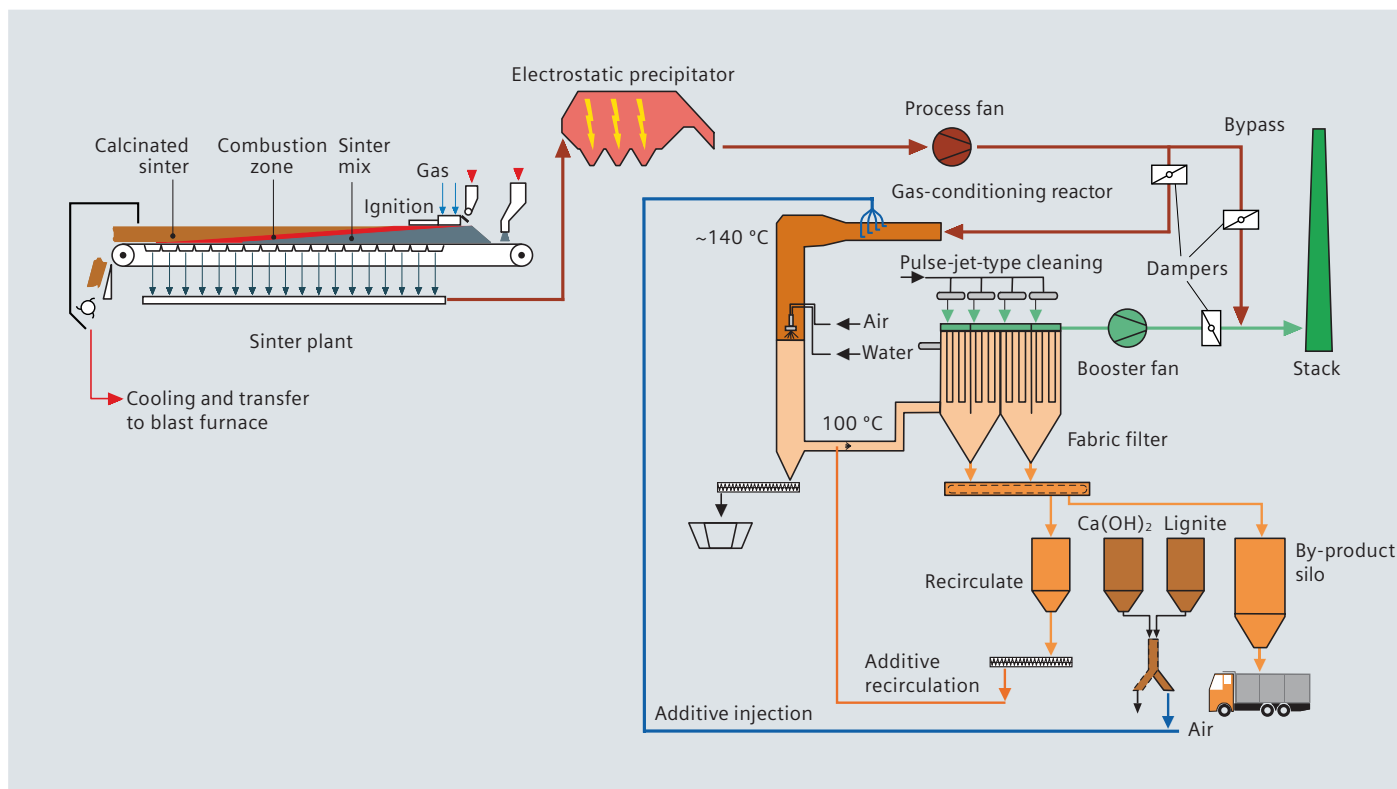

Principal process flow sheet of the SIMETAL^{CIS} MEROS® plant

SIMETAL^{CIS} MEROS process description

SIMETAL^{CIS} MEROS, an acronym for Maximized Emission Reduction Of Sintering, is a new environmental process characterized by a series of treatment steps in which dust, acidic gases and harmful metallic and organic components still present in the sinter offgas after the electrostatic precipitator are further reduced to previously unattained levels.

In the first step, special C-based adsorbents and desulphurization agents (hydrated lime) are injected into the sinter offgas stream in the counter-current direction to bind heavy metals and organic compounds.

In the second step, the gas stream passes to a conditioning reactor where the gas is moisturized and cooled to a temperature of about 100 °C by means of an injected fine mist using dual-flow, i.e., water and air, nozzles. This accelerates the chemical reactions required for binding and removing SO₂ and other acidic gas components.

In the third step, the off-gas stream which exits the conditioning reactor passes through a bag filter equipped with special high-performance fabrics where the dust with the trapped pollutants is removed. In order to enhance the gas-cleaning efficiency and to significantly reduce additive costs, a portion of this dust is recycled to the offgas stream after the conditioning reactor. This also accelerates the formation of a filter cake on the surface of the bag filter which enhances the removal of fine dust in the offgas stream. The dust removed from the system is conveyed to intermediate storage silos for subsequent disposal or for use in other applications.

Main benefits:

- High removal efficiency for heavy metals, acid gases and dioxin/VOC due to countercurrent flow injection of additives
- Low quantity of recirculation dust, therefore fewer filter pulse-cleaning cycles and less compressed air required for filter cleaning
- Avoidance of system sticking due to dry dust recirculation
- Reduced mechanical stress to filter bags applying low-pressure cleaning pulses
- Controlled and constant process temperature as the basis for efficient desulphurization
- Flexible gas desulphurization with Ca(OH)₂, supported by NaOH in the case of peak concentrations
- Reduced filter space requirements using eight-meter filter-bag lengths

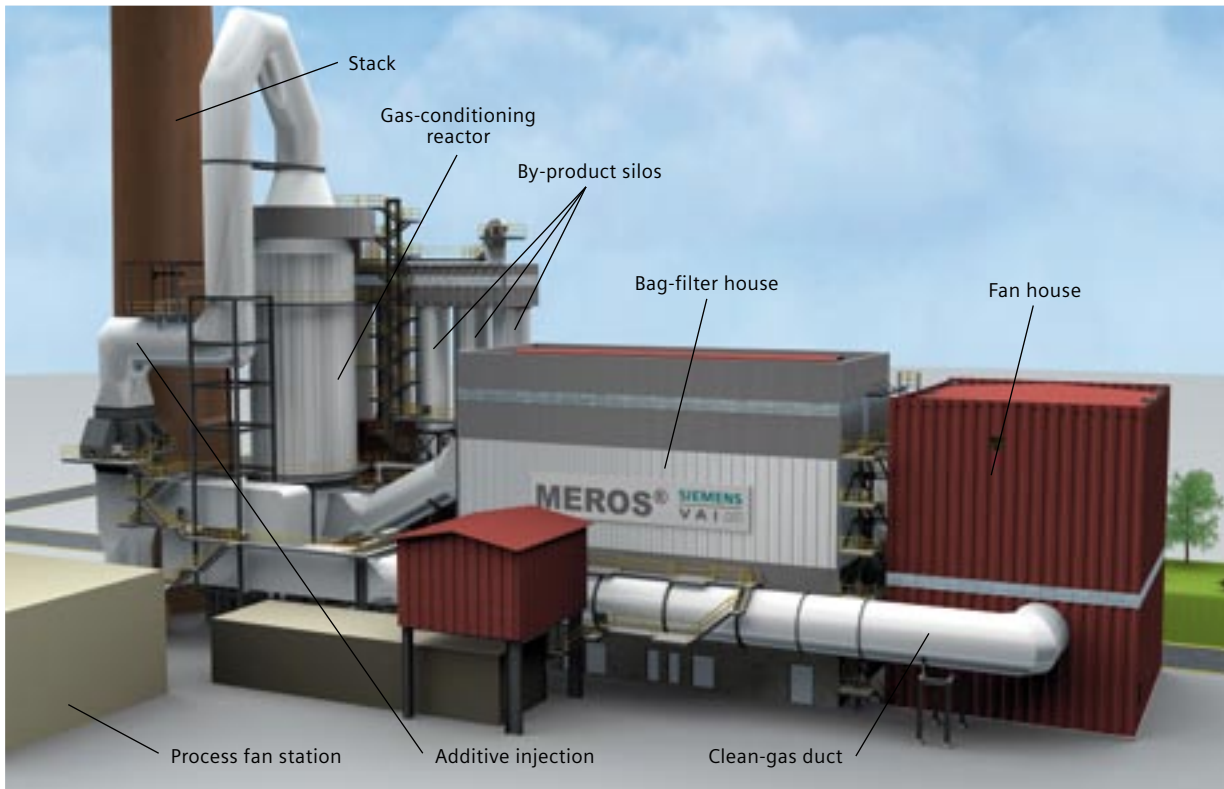

Schematic view of the SIMETAL^{CIS} MEROS plant

Project description

On the basis of successful results achieved in a series of test campaigns and optimization of the process parameters in a demonstration plant, voestalpine Stahl decided to install a full-scale industrial SIMETAL^{CIS} MEROS plant at their sinter plant in Linz, Austria. The project was implemented by Siemens VAI on a process-turn-key basis from April 2006 to August 2007. The entire project was carried out with minimal interference to normal sintering and gas-cleaning operations. A total shut-down period of less than five days was necessary for the modification and integration work with the existing gas-cleaning system. The plant started up on time in accordance with the contract schedule on March 17, 2007. Up to 1,000,000 m³/h of sinter off-gas can now be efficiently treated.

Project schedule:

- Receipt of contract: March 2006
- Start of engineering: April 2006
- Start of erection: October 2006
- Start-up: August 2007

Scope of supply & services:

- Process turnkey supply
- Project management
- Basic and detail engineering
- Purchase and supply of all equipment
- Process control and automation
- Mechanical & electrical installation
- Supervision of erection and commissioning
- Training



SIMETAL^{CIS} MEROS gas conditioning tower

Competence in figures

A Siemens VAI success story at voestalpine Stahl



Sinter plant and SIMETAL^{CS} MEROS[®] control room

In the SIMETAL^{CS} MEROS process sinter offgas emissions are reduced to levels previously unachieved applying convention gas-cleaning technologies. Dust emissions are lowered by more than 99% to less than five milligrams per Nm³. Emissions of mercury and lead are reduced by 97% and 99% respectively. Organic compounds such as dioxins and furans (PCDD/F) are eliminated by about 97% and total condensable VOCs by more than 99%. SO₂ emissions were also considerably reduced. During the first year of operation overall plant operational availability exceeding 99%. The results speak for themselves.

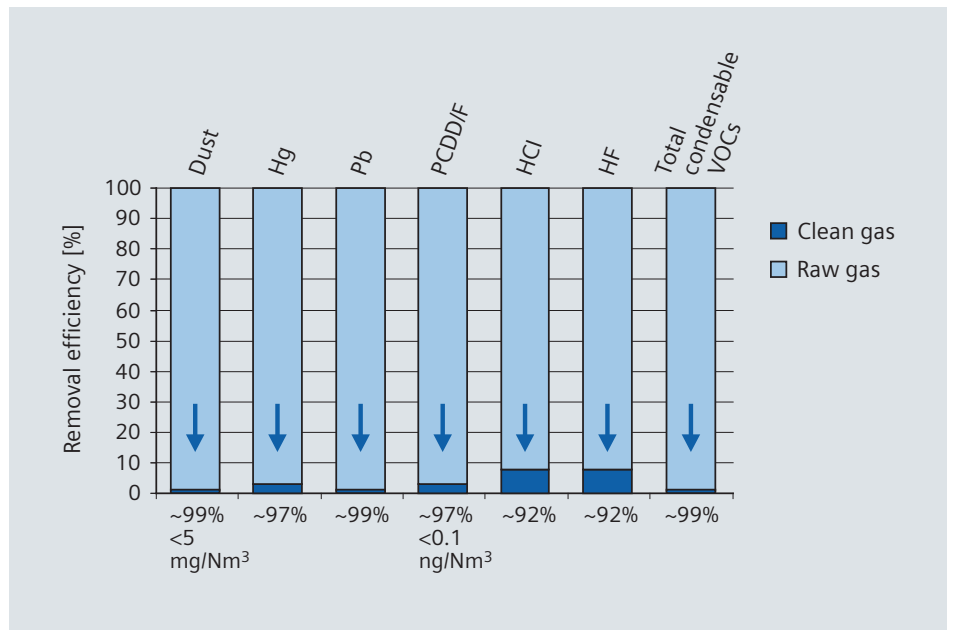

Sinter-gas-cleaning efficiency with SIMETAL^{CS} MEROS



SIMETAL^{GS} MEROS conditioning reactor and storage silos

**For further information,
please contact:**

Siemens VAI
Metals Technologies GmbH & Co
P.O. Box 4, Turmstr. 44
4031 Linz, Austria
Phone: +43 732 6592 77125
Fax: +43 732 6980 77125
E-mail: environmental.metals@siemens.com

The information provided in this brochure contains merely general descriptions or characteristics of performance which in actual case of use do not always apply as described or which may change as a result of further development of the products. An obligation to provide the respective characteristics shall only exist if expressly agreed in the terms of contract.

Order No.: E10001-M3-A47-V1-7600
Printed in Austria
Dispo No.: 21661 K-No.: 28103
SPS SVAI-08-00077 RF 09081.
Subject to change without prior notice

©Siemens AG 2008.
All rights reserved.

SIMETAL is a trademark of Siemens AG
CIS = Completely Integrated Solutions